



## **Street Cars Competition Rules**

**Version 1.9 : Effective 1<sup>st</sup> April 2010**

## INDEX

<b>1</b>	<b>GENERAL</b>	<b>1</b>
<b>2</b>	<b>AUTHORITY</b>	<b>1</b>
<b>3</b>	<b>PROMOTER</b>	<b>1</b>
<b>4</b>	<b>VEHICLE COMPETITION CLASSES</b>	<b>1</b>
<b>5</b>	<b>SCRA COMPETITION REGISTRATION</b>	<b>2</b>
<b>6</b>	<b>ELIGIBILITY</b>	<b>2</b>
<b>7</b>	<b>COACHWORK</b>	<b>2</b>
7.1	Mudguards	2
7.2	Aerodynamic aids	3
7.3	Body Panels	3
7.4	Firewall / Bulkheads	4
7.5	Floor Pan	4
<b>8</b>	<b>MECHANICAL COMPONENTS</b>	<b>5</b>
8.1	Suspension and Chassis	5
8.2	Transmission	5
8.3	Engine	5
<b>9</b>	<b>WHEELS AND TYRES</b>	<b>5</b>
<b>10</b>	<b>ELECTRICAL SYSTEM</b>	<b>6</b>
<b>11</b>	<b>MINIMUM RACING WEIGHTS</b>	<b>6</b>
<b>12</b>	<b>VEHICLE MARKINGS</b>	<b>7</b>
	<b>APPENDIX A</b>	<b>8</b>
	<b>APPENDIX B</b>	<b>9</b>

# Street Cars Competition Rules

## CAMS Group- 3D Sports Sedans with restrictions

These rules shall govern all Street Car competitions promoted in the State of Western Australia by the "The Street Car Racing Association" (SCRA) by authority of the Confederation of Australian Motor Sport (CAMS).

### 1 GENERAL

- (a) The Street Cars are a specific class of Automobile being based on the Regulations detailed in Specifications of Automobiles - Group 3D - Sports Sedans (Group 3D Regulations) as detailed in the CAMS Manual of Motor Sport with varied eligibility criteria as outlined in these Street Cars Competition Rules (Rules).
- (b) All vehicles must comply to these Rules and unless otherwise provided in all other matters the Group 3D Regulations shall apply.
- (c) This specific class envisages a degree of modification to automobiles so as to render them more suitable for competition without modification to the external body shape except as specifically allowed for in these Rules.
- (d) Vehicles must conform with General Requirements of Automobiles (as applicable) as detailed in Schedules A,B and in races, C of the CAMS Manual.
- (e) Four wheel drive vehicles where fitted with active centre differentials as standard may be retained - and if retained must remain unmodified. Electronic traction and /or brake and /or handling devices are prohibited.

### 2 AUTHORITY

Street Car race meetings shall be conducted under the International Sporting Code of the Federation Internationale de l'Automobile (F.I.A), the National Competition Rules (NCR) of CAMS, the Race Meeting Standing Regulations as detailed in the CAMS Manual and the relevant Supplementary Regulations and any further regulations or instructions that may be issued (see NCR 61).

### 3 PROMOTER

The promoter of the Street Car competition is known as **The Street Car Racing Association** (SCRA).

### 4 VEHICLE COMPETITION CLASSES

Competition classes for Street Cars are as follows:

- (a) **Outright** – All vehicles over 2000cc in engine capacity as calculated in accordance with the Group 3D Regulations.
- (b) **Under 2L** – All vehicles under 2000cc in engine capacity as calculated in accordance with the Group 3D Regulations.

## 5 SCRA COMPETITION REGISTRATION

To be eligible to score points competing in SCRA races both driver and entrant must be financial members of the CAMS affiliated club.

## 6 ELIGIBILITY

- (a) The onus of proof of vehicle eligibility rest with the individual competitor at all times.
- (b) All Street Car competition vehicles to be eligible to compete must comply with these Rules and unless otherwise stated by these Rules, in accordance with the Group 3D Regulations.

## 7 COACHWORK

Coachwork for all Street Car competition vehicles to be eligible to compete must comply within these Rules and unless otherwise stated by these Rules in accordance with the Group 3D Regulations.

### 7.1 Mudguards

- (a) The flares may be extended in width up to a maximum of 50mm per side in excess of the original width of the body at the measured point.
- (b) From the reformed wheel arch the mudguard flare must merge from the allowed 50mm to 25mm by 50 percent of the length of flare, and thereafter merge with the original body at an included angle of not more than 45° (refer to Diagram 1)
- (c) Original factory produced flares are acceptable.
- (d) The mudguard and/or flare may be modified to permit the exhaust pipe outlet to pass through a cut-out/relief therein, which must not be a hole, and which is located forward of the rear wheel, such that no part of the modification is above a horizontal plane passing through the centre of the rear wheel hub.

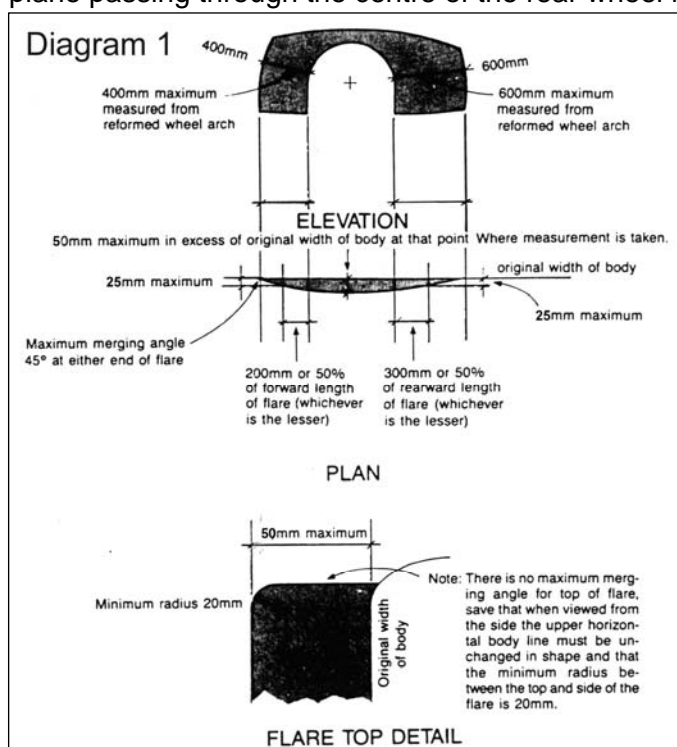

## 7.2 Aerodynamic aids

- (a) Front spoiler / airdam : Any undertray fitted to the airdam and located further than 50mm from the extremity of the airdam shall be flat, and parallel to the vehicle sills and shall be regarded as part of the front airdam. Standard manufacturer factory installed undertrays are permitted and must remain unmodified.
- (b) Rear Wing (factory std); rear wing assemblies fitted as factory standard by the vehicle manufacturer are permitted but must remain unmodified.
- (c) Rear Wing (non-std) for Mazda RX7 of model FD or later; it is permitted to fit a non-standard rear wing assembly provided that it is single element and complies to the dimensions in Diagram 2 (shown below). They also must not extend further rearward than the extremity of the rear bumper.
- (d) Rear Wing (non-std) for all other vehicles; it is permitted to fit a non-standard rear wing assembly provided that it is single element and complies to the dimensions in Diagram 3 (shown below). They also must not extend further rearward than the extremity of the rear bumper.
- (e) The fitment of custom or non-standard rear diffuser/undertray assemblies is not permitted. Standard manufacturer factory installed diffusers / undertrays are permitted and must remain unmodified.

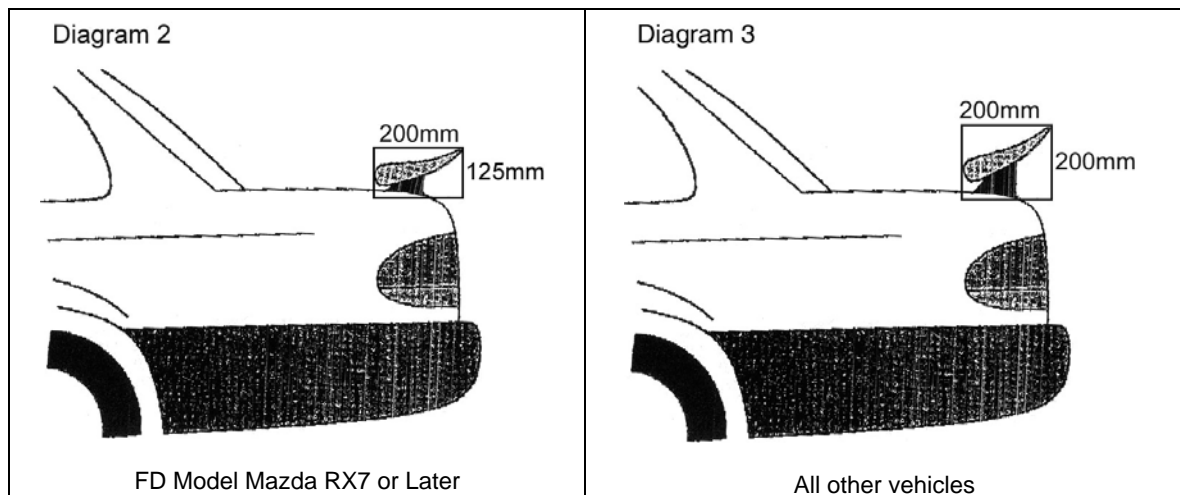

## 7.3 Body Panels

- (a) All body panels must remain original. Bonnet, boot lid and front fender guards may be replaced with alternative material, which must remain identical in external shape and form to the original and must also remain separate and detachable components.
- (b) Changes to the shape of the engine cover are not permitted.
- (c) Bonnet and mudguard air extraction: Where the original vehicle has no bonnet or front mudguard air outlets for extraction of air from under the bonnet and or front mudguard area, or if the original outlet/s is less than 500 square centimetres, then louvered venting may be added to the bonnet or mudguard/s subject to the following criteria:

- The maximum area the louvered area/s may occupy is 968 square centimetres;
- A maximum of two (2) vented areas may be added;
- The maximum height of any part of any vent is to be 25mm higher than the area of the immediately surrounding bonnet or mudguard;
- The maximum total width of the vent openings/raised sections is 220mm;
- The maximum total length of the vent openings/raised sections is 440mm.
- The following diagram details the maximum dimensions if only one vent is added:

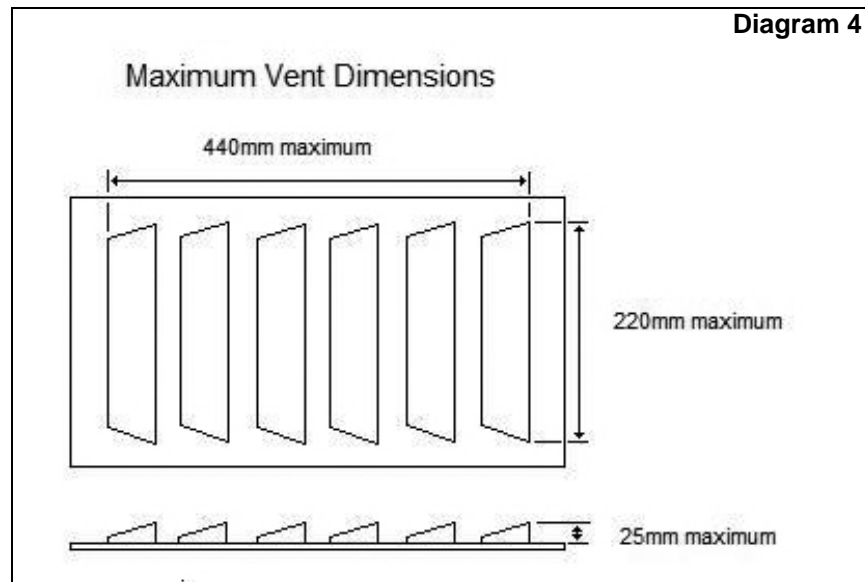

- (d) Front and Rear Doors; original front and rear door frames must be retained and must be unchanged in the areas not covered by the original door trim. All window regulator mechanisms may be removed. Original front door hinges and catches must be retained. Internal anti-theft locks must be rendered inoperative.

#### 7.4 Firewall / Bulkheads

The front firewall/bulkheads must remain substantially unaltered apart from local modification to permit the fitment of alternative engine/gearbox assemblies. Any additional material is to be of the same type, composition and thickness as the original part. Any rearward protrusion is not to exceed 100mm, and must be local in nature. The moving rearward of the complete firewall/bulkhead or engine is not permitted.

#### 7.5 Floor Pan

- (a) It is prohibited to include any vertical or near vertical vanes or other aerodynamic devices. Holes of a minimum necessary size may be made for the fitment of mechanical or suspension associated components or attachment purposes, or as otherwise provided in the 3D Regulations.
- (b) The rear beaver panel and/or bumper bar, whichever is the lower must remain original in shape and position.
- (c) The maximum radius of the rear wheel arches or inner guards must not be increased. It is permitted to extend the metal work from the maximum radius to the existing exterior coachwork.

## 8 MECHANICAL COMPONENTS

For all Street Car competition vehicles to be eligible to compete installed mechanical components must comply within these Rules and unless otherwise stated by these Rules in accordance with the Group 3D Regulations.

### 8.1 Suspension and Chassis

- (a) The chassis and sub-frame must be as original apart from the modifications these Rules allow. Space frames are prohibited unless originally used by the vehicle manufacturer.
- (b) Rear axle assemblies must remain the same as the manufacturer type however leaf spring type may be replaced with coil over type. Mounting points are free.
- (c) Front suspension assemblies must remain the same as the manufacturer type but mounting points are free.

### 8.2 Transmission

- (a) The gears must be selected by the driver exclusively via a non-sequential mechanical linkage. This permits "H" pattern gear change mechanisms only.
- (b) All model Mazda RX7 permitted synchromesh engagement gears only.

### 8.3 Engine

Engines and ancillary equipment are free provided that the engine is from the original vehicle manufacturer and has the same number of cylinders or rotors as the original engine.

## 9 WHEELS AND TYRES

For all Street Car competition vehicles to be eligible to compete fitted wheels and tyres must comply within these Rules and unless otherwise stated by these Rules in accordance with the Group 3D Regulations.

- (a) The maximum rim width and minimum tyre aspect ratio for vehicles will be as per the tables in APPENDIX A and APPENDIX B - and will be a factor in determining the minimum racing weight.
- (b) The control tyre Outright Vehicle Competition Class (Over 2L) is to be specified by the SCRA after completion of the approved open tender process conducted with the approval of CAMS.

The current Outright Vehicle Competition Class control tyre is the Bridgestone RE55S (SR2 Compound Only).

- (c) The eligible tyres for the Under 2L Vehicle Competition Class is as per the CAMS Production Car Tyre List – 'Schedule E'.

- (d) The tread wear indicators as provided by the tyre manufacturer will be the definitive method of determining minimum tread depth. At no stage prior to practice or racing may any tread wear indicator be exposed or in the case where the indicator is a dimple in the tyre, worn below such indicator.

## 10 ELECTRICAL SYSTEM

For all Street Car competition vehicles to be eligible to compete installed electrical systems must comply within these Rules and unless otherwise stated by these Rules in accordance with the Group 3D Regulations.

- (a) Lighting equipment must retain its original external appearance. The headlamps must function on at least one beam, each lamp of 35 watts minimum power. Tail lamps and brake lamps must remain operable, with a minimum power of three and 20 watts respectively.
- (b) On cars originally fitted with a retractable headlamp system, the outer body panel of the headlamp may be replaced by rigid transparent material not less than 3mm thick, so that a lamp may be mounted in a fixed position such that it can be seen from the front of the car. The headlamp actuating system may then be removed.

## 11 MINIMUM RACING WEIGHTS

- (a) The minimum racing weight for two wheel drive vehicles at any time including the driver and wearing all apparel will be determined by the capacity of the engine, rim width and tyre aspect ratio (Base minimum weight table) including (plus or minus where applicable) any supplementary weight (Supplementary minimum weight requirement table) as per APPENDIX A.
- (b) The minimum racing weight for four wheel drive vehicles at any time including the driver and wearing all apparel will be determined by the capacity of the engine, rim width and tyre aspect ratio (Base minimum weight table) as per APPENDIX B.

These weights may be revised by the Street Car Racing Association.

## 12 VEHICLE MARKINGS

Each vehicle shall display the minimum weight (in whole kilograms), maximum rim width (in whole inches) and minimum tyre aspect ratio (as a percentage) as per APPENDIX A for two wheel drive vehicles and APPENDIX B for four wheel drive vehicles at all times during competition events. This number shall be known as the "*Weight Number*".

- (a) The *Weight Number* displayed will be formatted and comprise of the following information:

**MINIMUM\_WEIGHT - MAXIMUM\_RIM\_WIDTH - MINIMUM\_TYRE\_ASPECT\_RATIO**

- (b) The displayed *Weight Number* shall be black text on a white background. Minimum height of the text is 35mm and it shall be formed from either "Helvetica Bold", "Zurich Bold" or "Arial Bold" typestyles.
- (c) The size of the displayed *Weight Number* and background shall be in accordance with Diagram 4 or Diagram 5. The location of the *Weight Number* shall be within the highlighted area in accordance with Diagram 6 on the left-hand side of the vehicle.

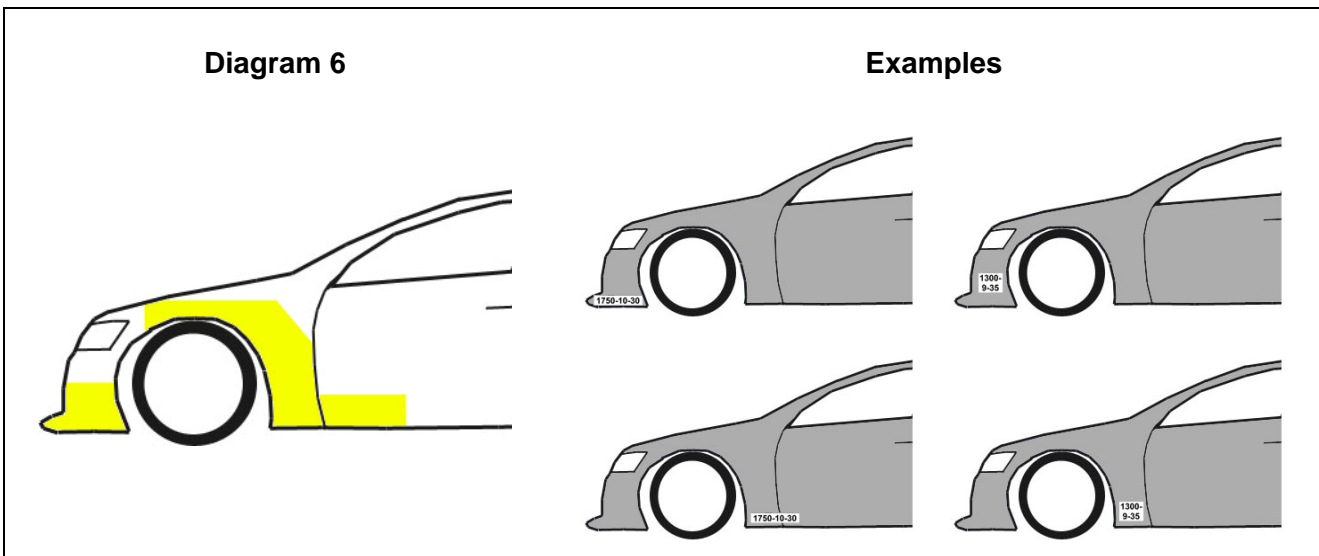
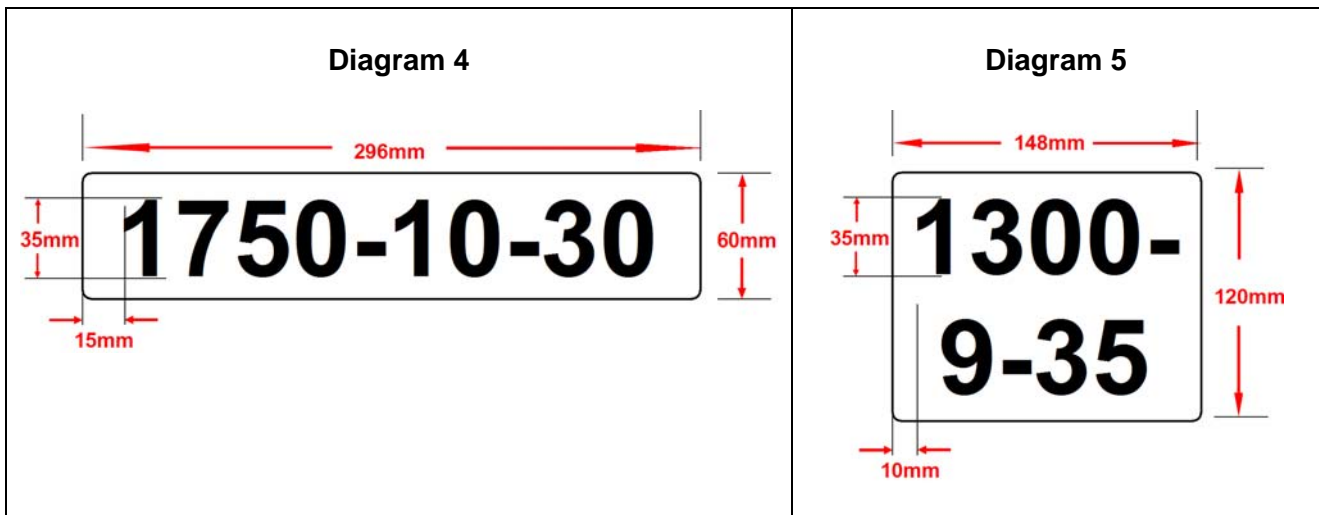

## APPENDIX A

<b>Two Wheel Drive Vehicles (2WD)</b>					
<b>Minimum Racing Weight</b>		<b>Maximum Rim Width / Minimum Tyre Aspect Ratio</b>			
		<b>7" / 50%</b>	<b>8" / 40%</b>	<b>9" / 35%</b>	<b>10" / 30%</b>
<b>Engine Capacity (cc)</b>	Up to 1600	<b>850</b> kg	<b>1000</b> kg	<b>1100</b> kg	<b>1200</b> kg
	1601 to 2000	<b>975</b> kg	<b>1125</b> kg	<b>1225</b> kg	<b>1325</b> kg
	2001 to 2500	<b>1000</b> kg	<b>1150</b> kg	<b>1250</b> kg	<b>1350</b> kg
	2501 to 3550	<b>1050</b> kg	<b>1200</b> kg	<b>1300</b> kg	<b>1400</b> kg
	3551 to 4500	<b>1100</b> kg	<b>1250</b> kg	<b>1350</b> kg	<b>1450</b> kg
	4501 to 5100	<b>1150</b> kg	<b>1300</b> kg	<b>1400</b> kg	<b>1500</b> kg
	5101 to 6000	<b>1200</b> kg	<b>1350</b> kg	<b>1450</b> kg	<b>1550</b> kg
<b>Supplementary minimum weight requirement (2WD Vehicles Only)</b>					
Vehicles Model Year 1978 to 1986		<b>Minus 50</b> kg			
Vehicles Model Year 1977 or earlier		<b>Minus 100</b> kg			
Mazda RX7 for Model FD or later		<b>Plus 120</b> kg			

## APPENDIX B

<b>Four Wheel Drive Vehicles (4WD)</b>					
<b>Minimum Racing Weight</b>		<b>Maximum Rim Width / Minimum Tyre Aspect Ratio</b>			
		<b>7" / 45%</b>	<b>8" / 35%</b>	<b>9" / 30%</b>	<b>10" / 30%</b>
<b>Engine Capacity (cc)</b>	<b>Up to 2000</b>	<b>1150 kg</b>	<b>1250 kg</b>	<b>1350 kg</b>	<b>1450 kg</b>
	<b>2001 to 2500</b>	<b>1250 kg</b>	<b>1350 kg</b>	<b>1450 kg</b>	<b>1550 kg</b>
	<b>2501 to 3550</b>	<b>1300 kg</b>	<b>1400 kg</b>	<b>1500 kg</b>	<b>1600 kg</b>
	<b>3551 to 4500</b>	<b>1350 kg</b>	<b>1450 kg</b>	<b>1550 kg</b>	<b>1650 kg</b>
	<b>4501 to 5100</b>	<b>1400 kg</b>	<b>1500 kg</b>	<b>1600 kg</b>	<b>1700 kg</b>
	<b>5101 to 6000</b>	<b>1450 kg</b>	<b>1550 kg</b>	<b>1650 kg</b>	<b>1750 kg</b>